

Teacher Made Gift

M

Memory Cards

1

- 24 cards ready to print, cut, and gift
- Blank templates for personalization
- Use as surprize gift or class project
 - Eight shapes,
 - Numbers 0 to 9
 - Letters to spell Memory
- Instruction booklet ready to copy, cut and fold

2

m

3

o

4

r

y

5

A Fresh Look at Education



UnCommon-Core.com

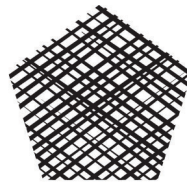
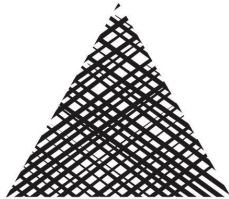

Isabelle Hoag M. Ed.
Director of Education
UnCommon-Core.com

Hello Teachers,

Thank you for downloading this handout. After decades of teaching, now I am sharing some of the activities I designed for my students and some new ones as well.

Please, check out the self-paced teacher education courses on UnCommon-Core.com.

While you are there, sign up for your free copy of **Colorful Collections: A Mindful Exploration of Proper Fractions**.

Also, visit my Teachers Pay Teachers store UnCommon-Core dot com.

Thank you again. All the best,

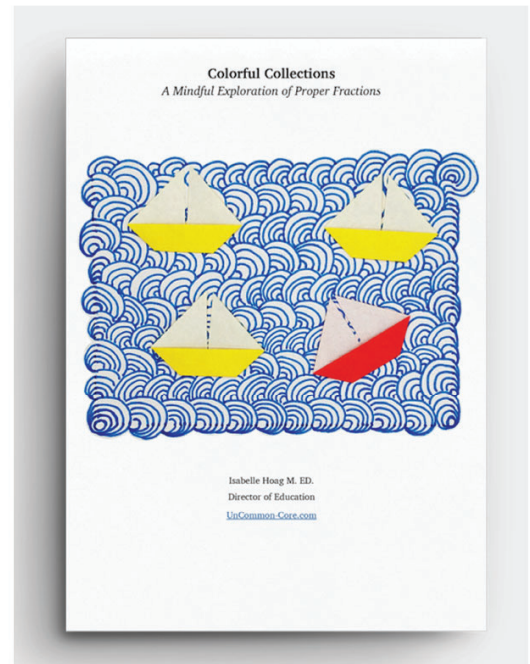

Isabelle

Isabelle Hoag M.Ed.
Director of Education
UnCommon-Core.com

Educational Gift for Winter Vacation

Would you like your students to keep learning over winter vacation?

Send them home with this fun, memory game. Playing games engages working memory. Children have to remember the rules of the game, when their turn comes around, and the location of cards that might match. Tracking all this information gives their working memory a workout. A strong working memory makes learning easier.

Preparation: Give yourself a week or more to assemble decks of memory cards for your students.

Decide how to package them for the trip home.

- Use the page of blank cards to complete the deck as you wish. You could: write each student's name on a card. Write math vocabulary words and a symbol or definition card to match with it.
- Practice printing cards front and back to make sure the copier is set up correctly. Use thick paper to conceal the designs from the back. Print pages 'actual size' for best results.
- Print the cards. Make sure there are two matching cards in each student deck.
- Print instruction pages back to back. Cut out and fold in half. Complete the gift tag on the front.
- Either use the paper cutter to create same sized memory cards for your students, or send home the pages with instructions for them to cut them apart at home. Alternatively, let the students cut out the cards at school while they listen to a story or watch an educational video.
- Keep the cards in colorful baggies, [an origami card holder](#), or a couple of rubber bands covered with ribbons. Include the personalized gift tag and instructions.
- Send them home with each student before winter break begins. That way everyone has something to keep them busy even if they miss a couple days before winter break.

Directions

Pages 5 and 6: Front of 12 cards

Page 7: Back of 12 cards

Page 8: Template for front or back of cards

Pages 9 and 10: Instruction booklet with gift tag front

Page 11: Optional Card Holder - use larger paper depending on number of cards in the deck

Please note: Do not change size or scale when copying. Print a single copy first to make sure everything is set up correctly.

For Each Student:

Make a set of Memory Cards:

Copy pages 5 and 7 back to back twice. Copy pages 6 and 7 back to back twice.

If you use both pages 5 and 6 there will be 24 cards with unique designs. Each card needs a match, so there should be 48 cards in total.

Copy pages 9 and 10 back to back. There are six instruction booklets on one page. Cut them out and fold in half. Include one booklet with each deck of Memory Cards.

6

7

8

9

M

e

m

o

r

y

5

4

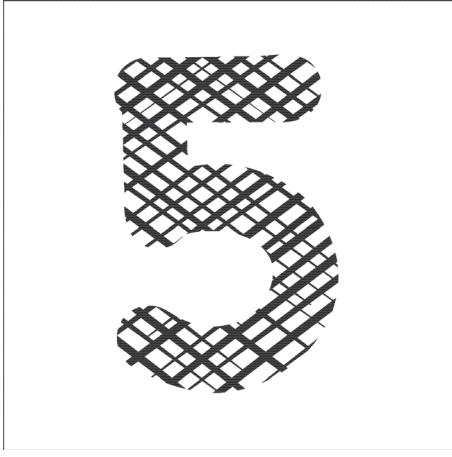
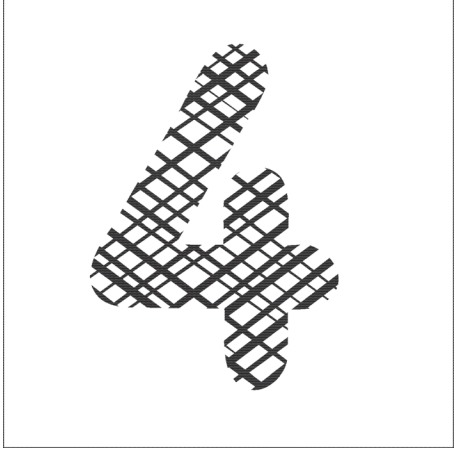
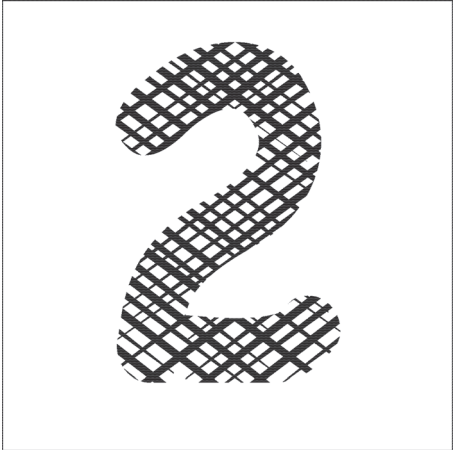
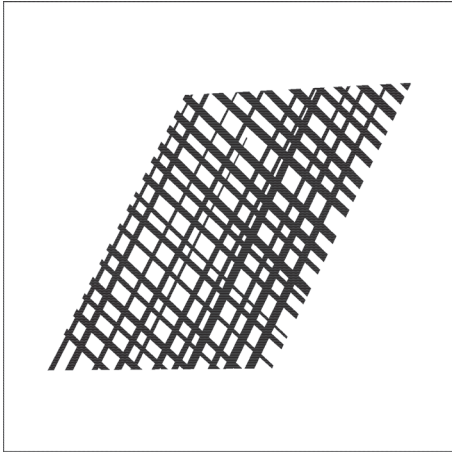
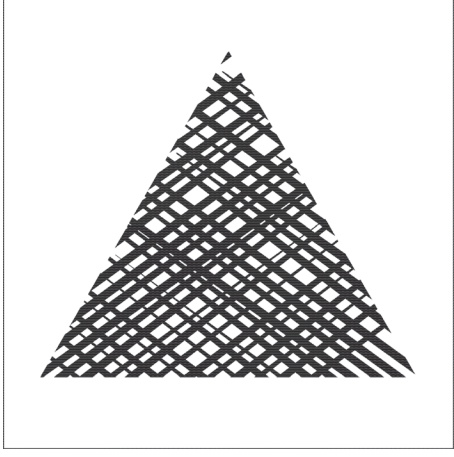
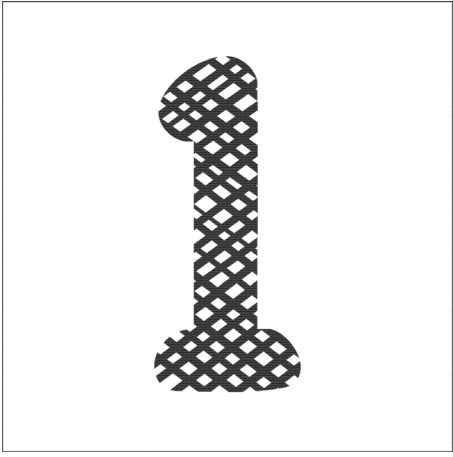
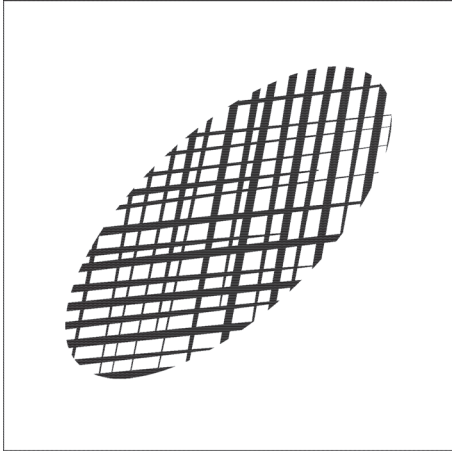
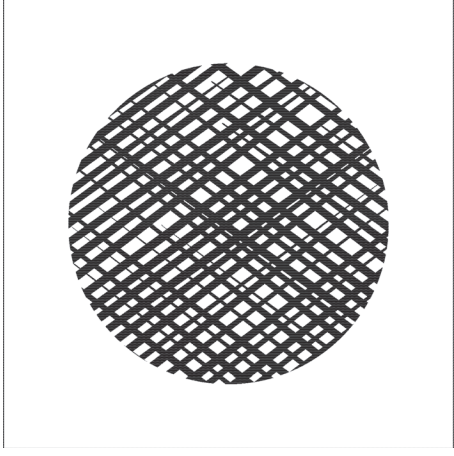
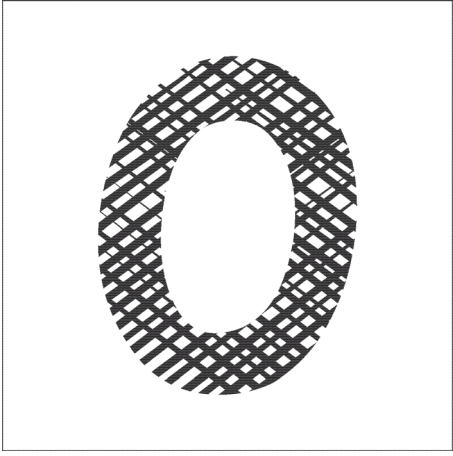
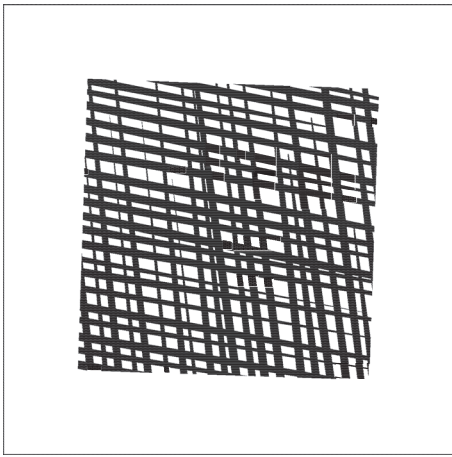
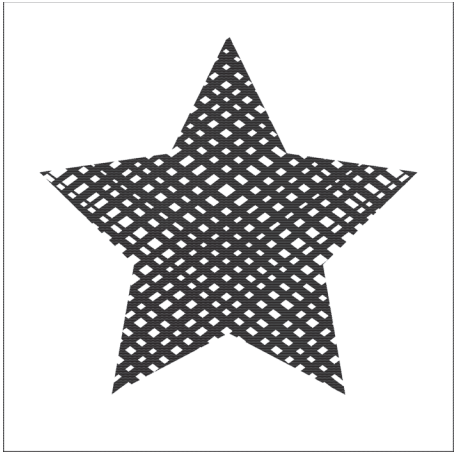

A Fresh Look at Education

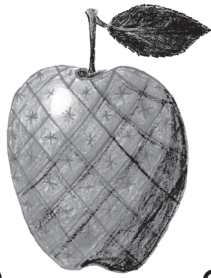

UnCommon-Core.com

A Fresh Look at Education



UnCommon-Core.com

A Fresh Look at Education



UnCommon-Core.com

A Fresh Look at Education

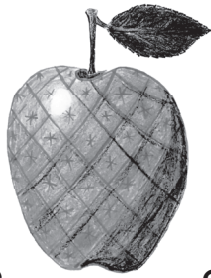

UnCommon-Core.com

A Fresh Look at Education

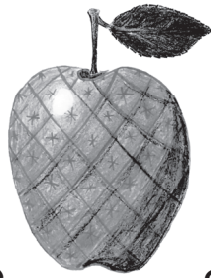

UnCommon-Core.com

A Fresh Look at Education



UnCommon-Core.com

A Fresh Look at Education



UnCommon-Core.com

A Fresh Look at Education



UnCommon-Core.com

A Fresh Look at Education



UnCommon-Core.com

A Fresh Look at Education

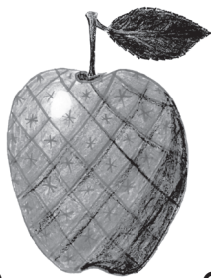

UnCommon-Core.com

A Fresh Look at Education

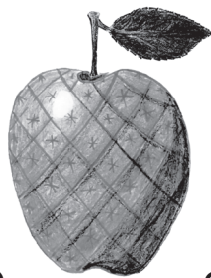

UnCommon-Core.com

A Fresh Look at Education



UnCommon-Core.com

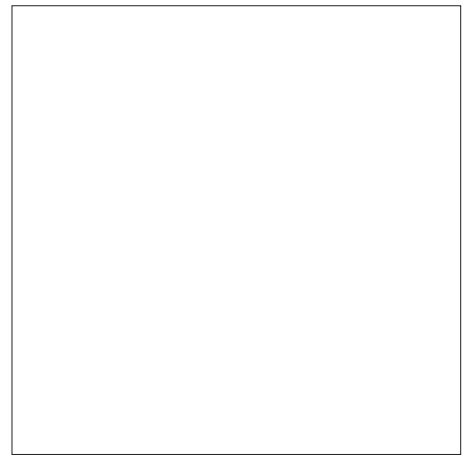
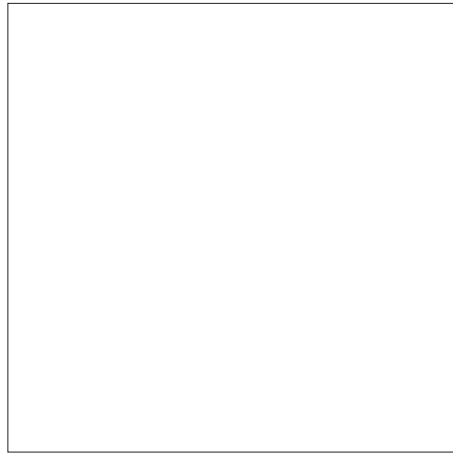
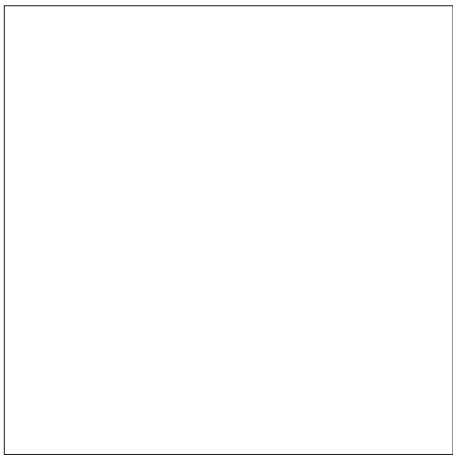
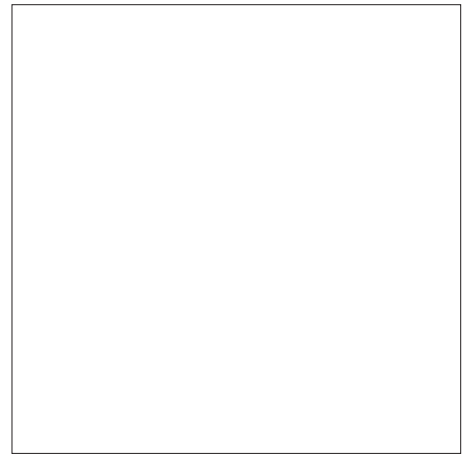
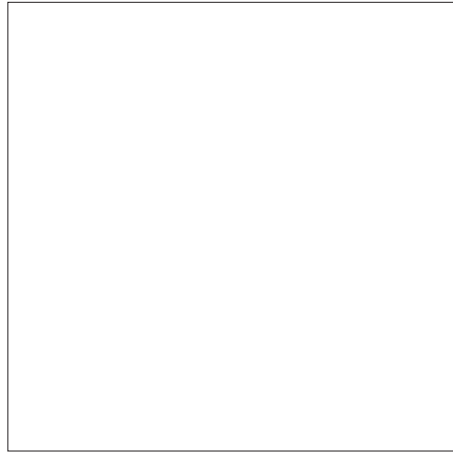
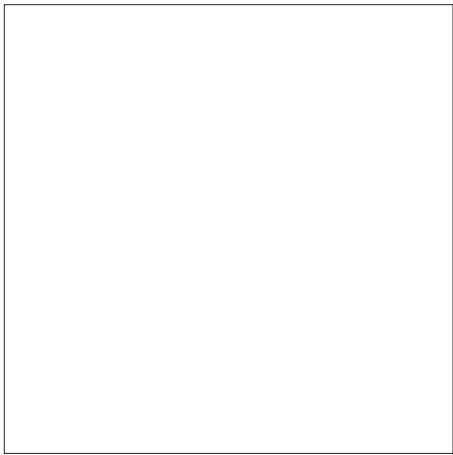
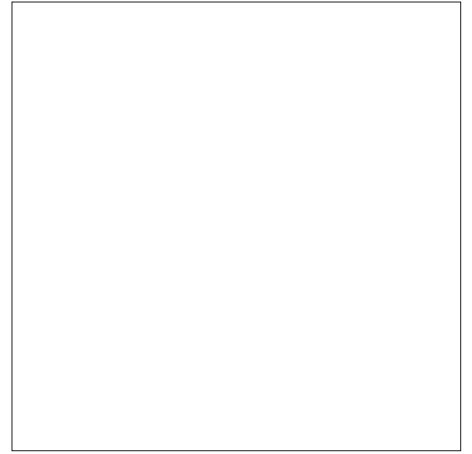
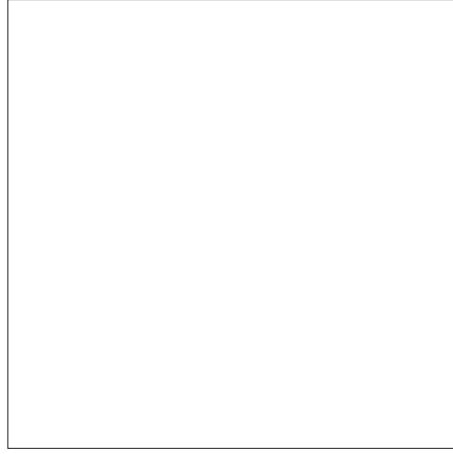
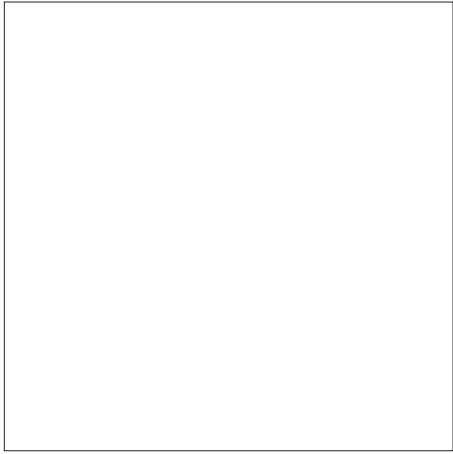
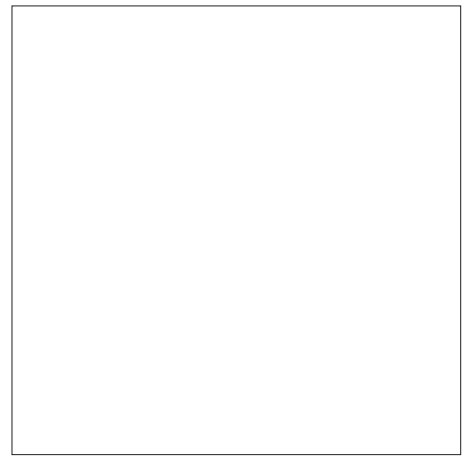
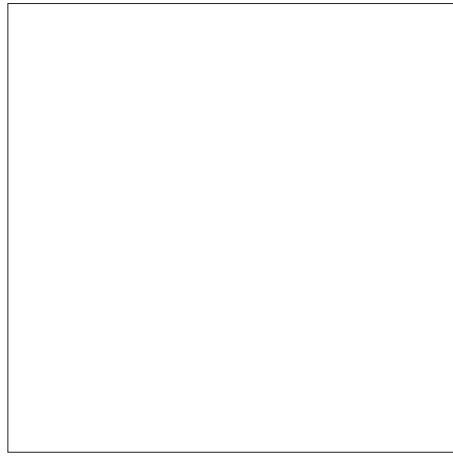
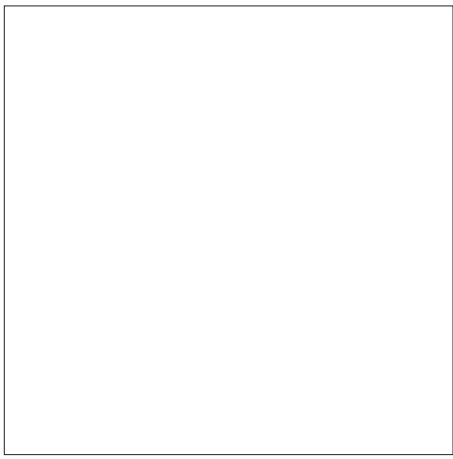

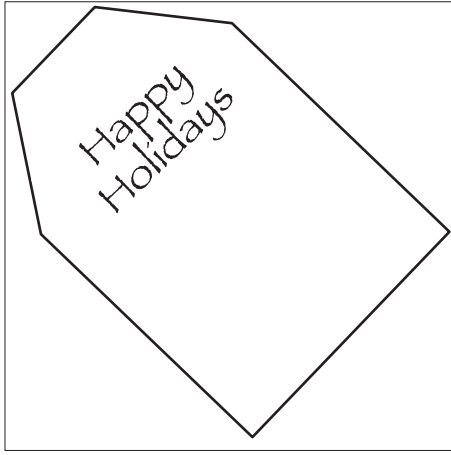
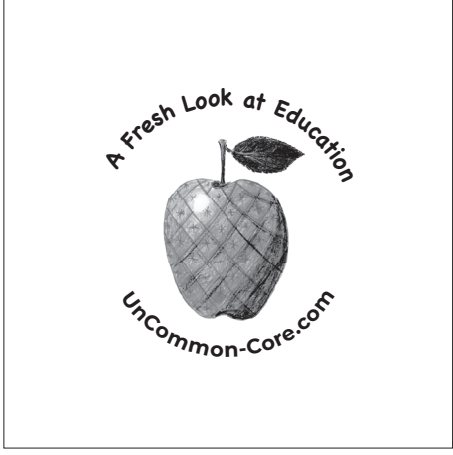
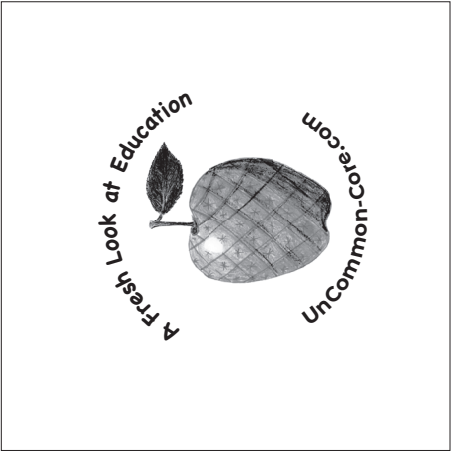
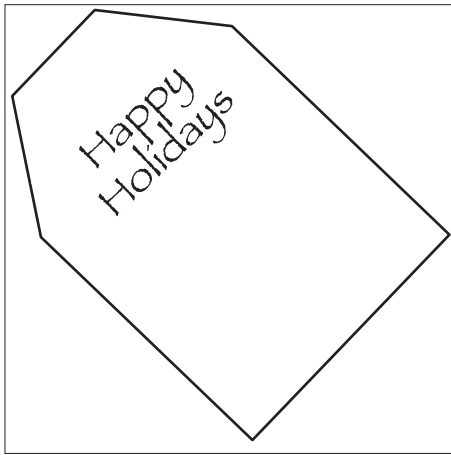
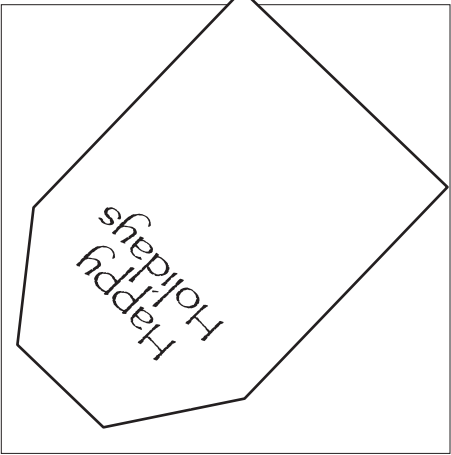
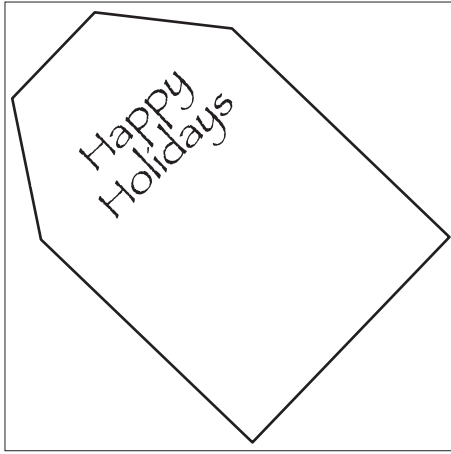
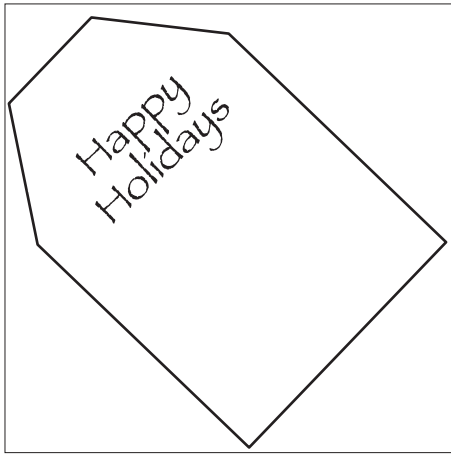
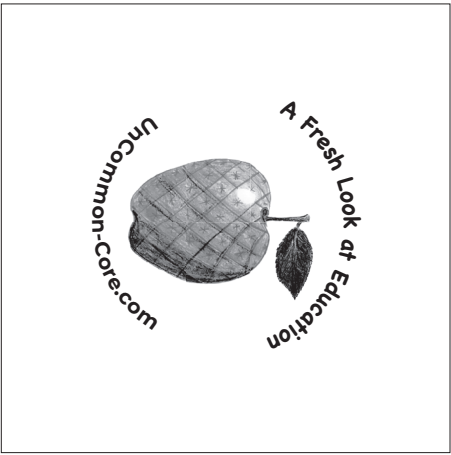

Memory

Play this game by yourself or with others.

Mix up the cards really well.

Place cards face down, in a rectangular shape.

Turn over a card - leave it in place. Then turn over another card.

If the cards match, you get to keep them and go again.

If they don't match, turn them face down again.

Memory

Play this game by yourself or with others.

Mix up the cards really well.

Place cards face down, in a rectangular shape.

Turn over a card - leave it in place. Then turn over another card.

If the cards match, you get to keep them and go again.

If they don't match, turn them face down again.

Memory

Play this game by yourself or with others.

Mix up the cards really well.

Place cards face down, in a rectangular shape.

Turn over a card - leave it in place. Then turn over another card.

If the cards match, you get to keep them and go again.

If they don't match, turn them face down again.

Memory

Play this game by yourself or with others.

Mix up the cards really well.

Place cards face down, in a rectangular shape.

Turn over a card - leave it in place. Then turn over another card.

If the cards match, you get to keep them and go again.

If they don't match, turn them face down again.

Memory

Play this game by yourself or with others.

Mix up the cards really well.

Place cards face down, in a rectangular shape.

Turn over a card - leave it in place. Then turn over another card.

If the cards match, you get to keep them and go again.

If they don't match, turn them face down again.

Memory

Play this game by yourself or with others.

Mix up the cards really well.

Place cards face down, in a rectangular shape.

Turn over a card - leave it in place. Then turn over another card.

If the cards match, you get to keep them and go again.

If they don't match, turn them face down again.

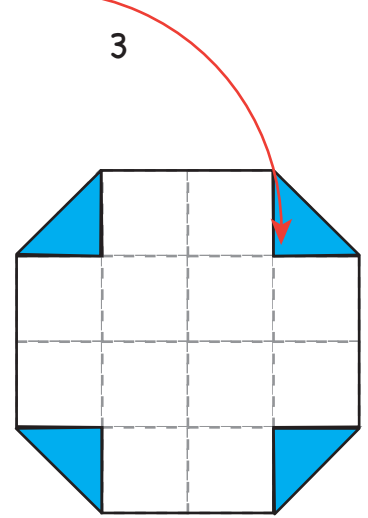
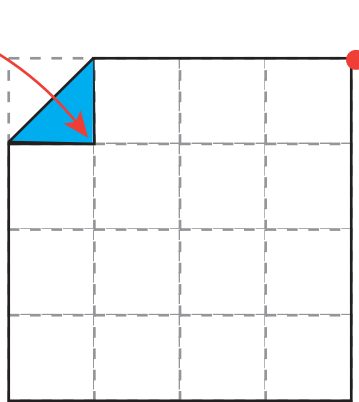
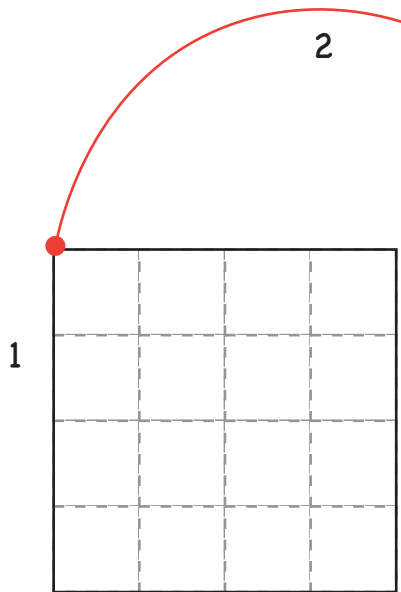

Memory Card Holder

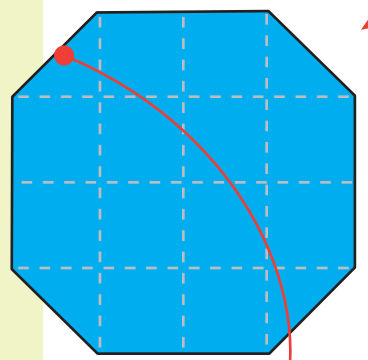

5

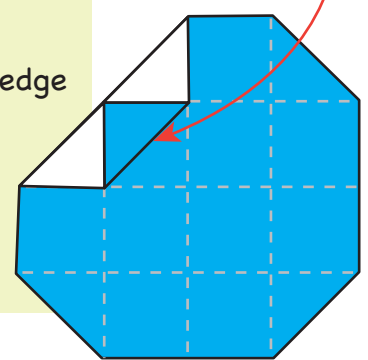

6

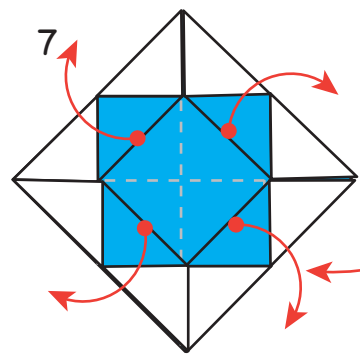

7

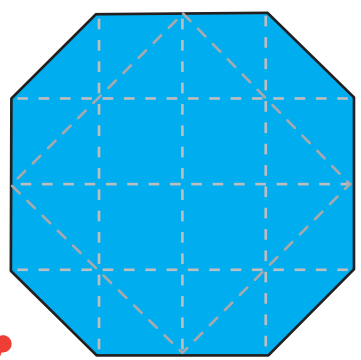

8



11

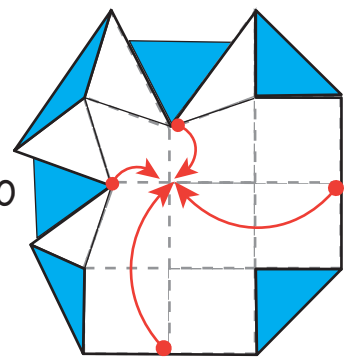

10

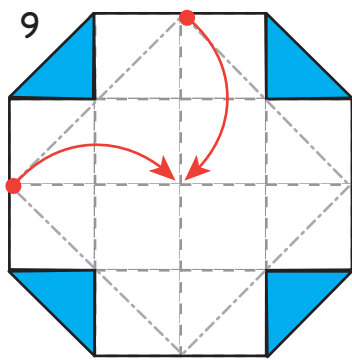

9

- 1 Start with a 6" by 6" piece of origami paper.
- Fold in half vertically and horizontally. Then bring each edge to the center and crease.
- 2,3 Fold corners as shown.
- 4 Flip model over.
- 5,6 Fold corners as shown. Then unfold.
- 7 Flip model over.
- 8 Collapse the midpoint of each edge into the center of the model.
- 10
- 11 The model has pockets on all four corners. Tuck the corners of a stack of Memory Cards into these pockets.

Terms of Use

By downloading this product, you agree that the contents are the property of Isabelle Hoag M. Ed., Director of Education at UnCommon-Core.com and licensed to you only for classroom/personal use as a single user. I retain the copyright, and reserve all rights to this product.

YOU MAY:

- Use this product with your own students, in your classroom, or for your own personal use.
 - Reference this product in blog posts, professional development workshops, at seminars, or other similar venues, ONLY if both credit is given to me as the author and a link to UnCommon-Core.com is included.
 - Please direct others to UnCommon-Core.com where they can download their own free copy.
-

YOU MAY NOT:

- Claim this work as your own, alter the files in any way or remove copyright/watermarks.
 - Sell the files or combine them into another unit for sale or for free.
 - Post this document for sale or free elsewhere on the internet including Google Doc links on blogs.
 - Make copies of this product to share with others.
-

Thank you for following universally accepted codes of professional ethics while using this product. If you have any issues with the file, or notice an error please contact me and I will be happy to help sort it out.

Thank you!

Isabelle@UnCommon-Core.com