

Be My Valentine



Step by Step Instructions
for Folding Paper Hearts

Hello Teachers,

Thank you for downloading this handout. After decades of teaching, now I am sharing some of the activities I designed for my students and some new ones as well.

Please, check out the self-paced teacher education courses on UnCommon-Core.com.

While you are there, sign up for your free copy of **Colorful Collections: A Mindful Exploration of Proper Fractions**.

Also, visit my Teachers Pay Teachers store UnCommon-Core dot com.

Thank you again. All the best,



Isabelle

Isabelle Hoag M.Ed.
Director of Education
UnCommon-Core.com

Fold a Valentine

There are **several options** when you decide to fold valentines in your class.

There is a colorful poster to share with the entire class and half page mini-posters for individual students. Most of the pages are offered in color and greyscale for copying.

Materials: scrap paper for practice, paper bags, magazines, any kind of paper cut in squares, (Have a template handy?) and origami paper in all sizes and colors. You might need clip boards, scissors, rulers, caryons, pens, pencils, glue sticks, and tape.

Set up step by step stations: Print the half page instructions and set up folding stations around the room. Invite your students to visit them in order, folding as they go.

Help students visualize each step - have a real paper model, folded up to that point at each station. Write "model" on the paper. Draw fold lines as needed. Students can see what their model should look like and practice the next fold on the model.

Fold some mega-models. Bring out some giant squares cut from bulletin board paper or wrapping paper. Let students work in teams to fold these huge hearts! Post them in the hall with some snapshots of your class folding valentines.

Invite helpers. Reading buddies? Parents?



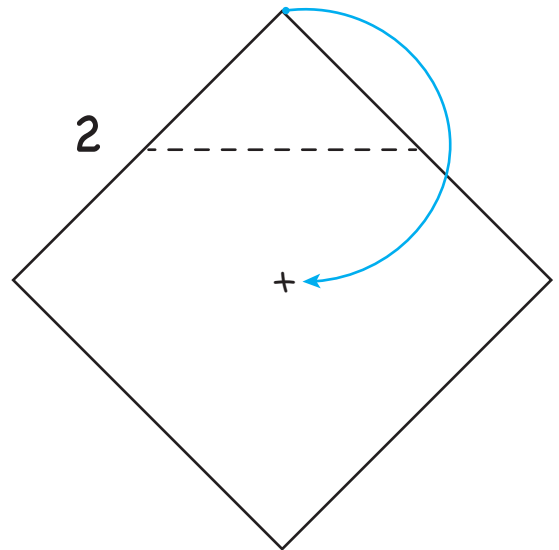
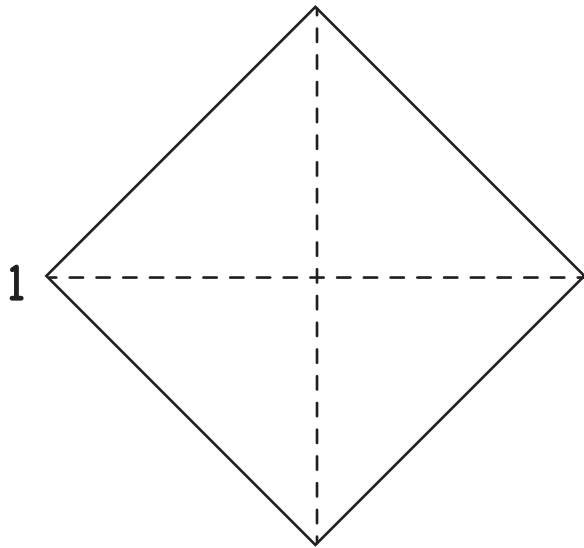

Fold a Valentine

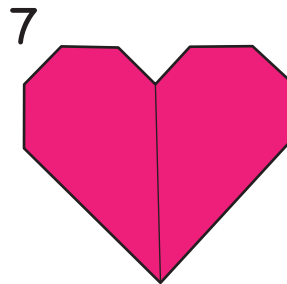
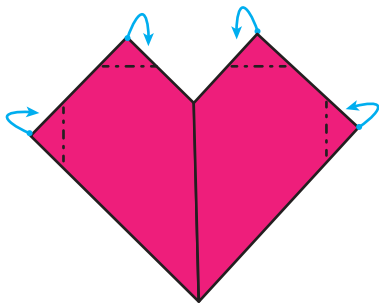
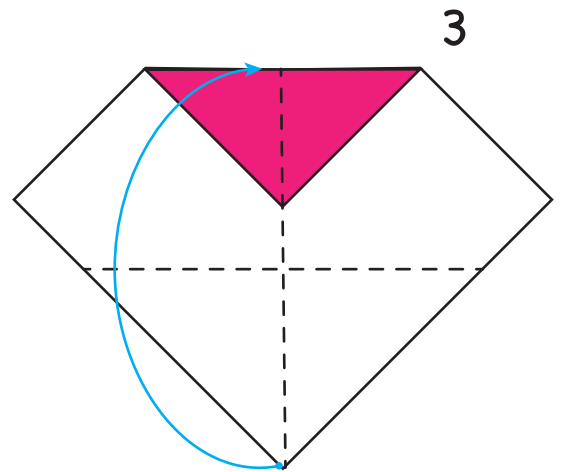

6

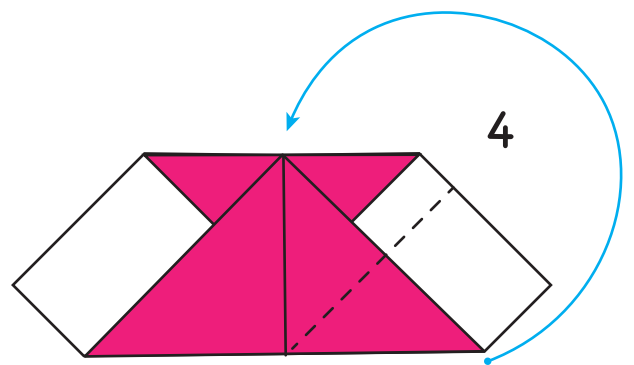
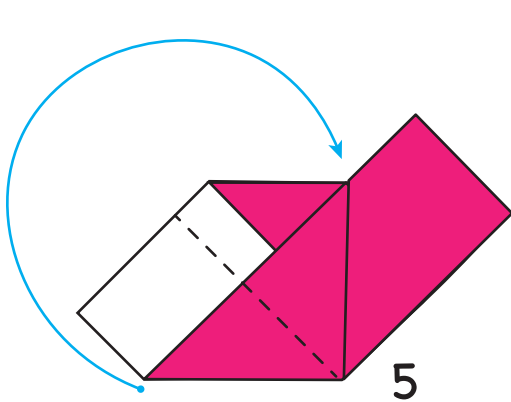

1

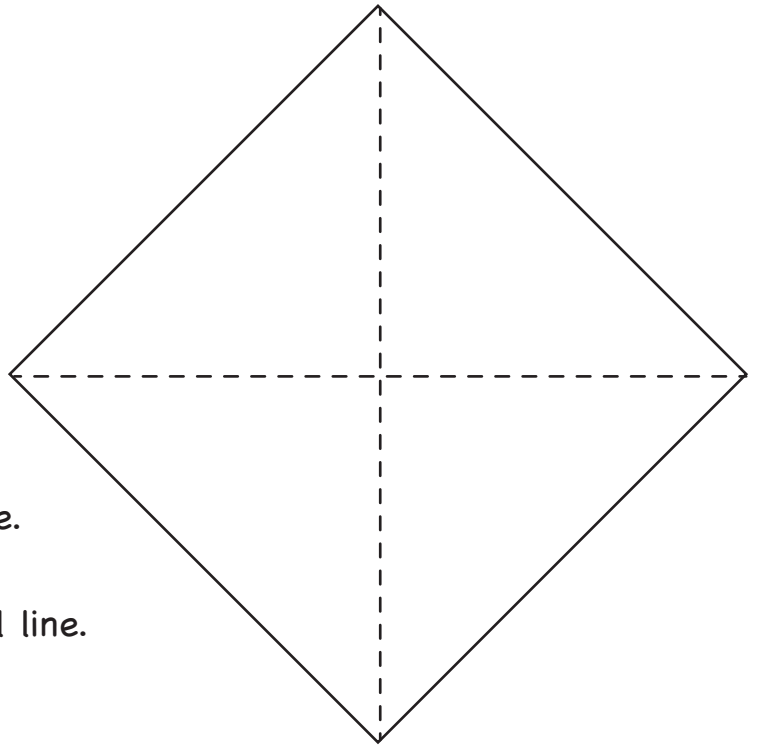

1. Bring opposite corners together.
2. Carefully fold the diagonal crease.
3. Open.
4. Repeat to fold the other diagonal line.

© 2023 UnCommon-Core.com



2

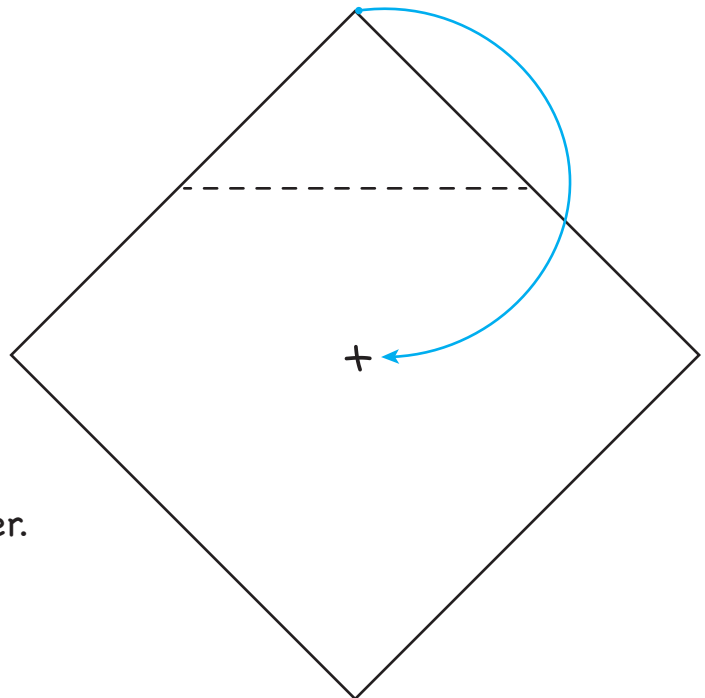

1. Bring the top corner to the center.
2. Crease the fold.

© 2023 UnCommon-Core.com

3

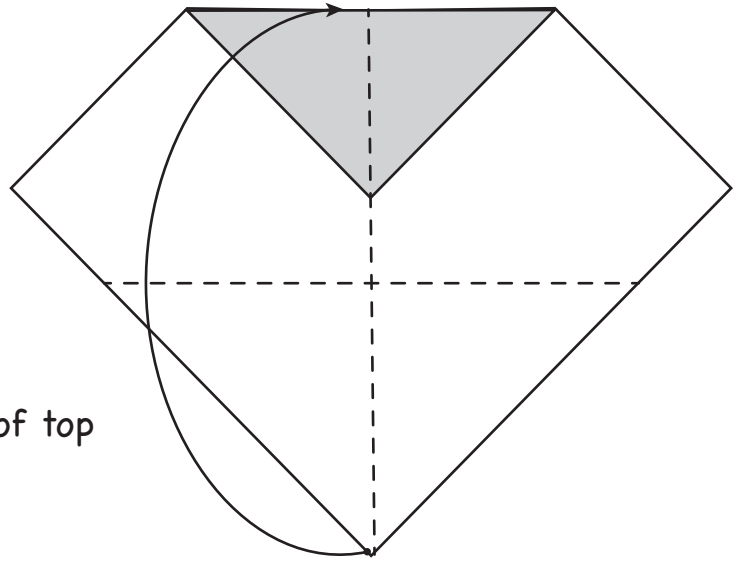

1. Bring bottom corner to center of top edge.
2. Crease the fold.
3. Notice that the perpendicular lines are the same length.

© 2023 UnCommon-Core.com



4

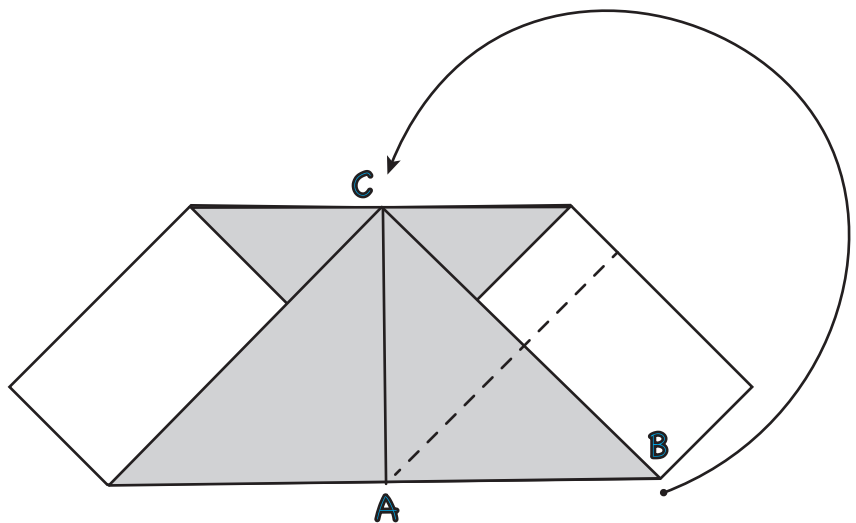

1. Use point A as a pivot.
2. Bring point B up to meet the center of the top edge at point C.
3. Match \overline{AB} to \overline{AC} very carefully.
4. Crease.

© 2023 UnCommon-Core.com

5

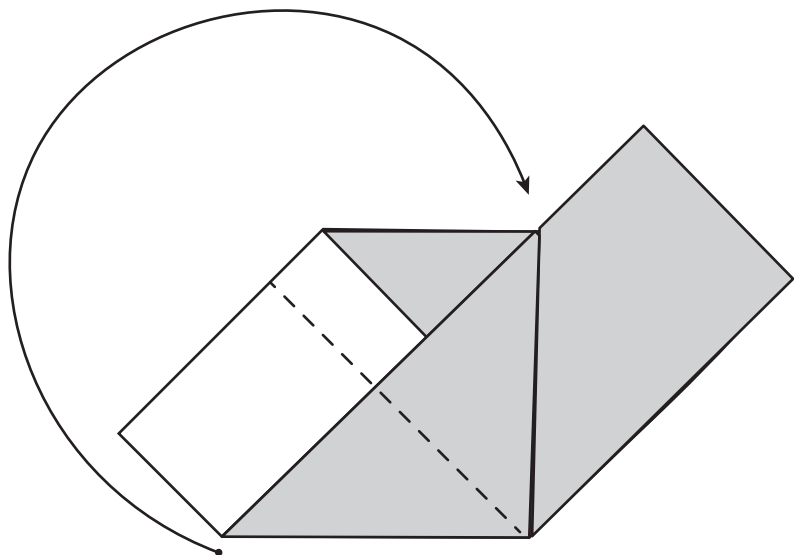

1. Repeat step 4 on the other side.

© 2023 UnCommon-Core.com



6

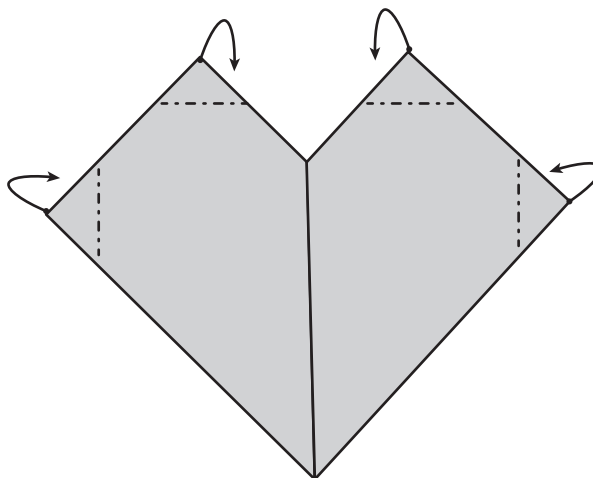

1. Fold the tip of each corner to the back as shown.
2. Write your name or initials on the back of your paper heart.
3. Try folding another heart from memory.

© 2023 UnCommon-Core.com

3

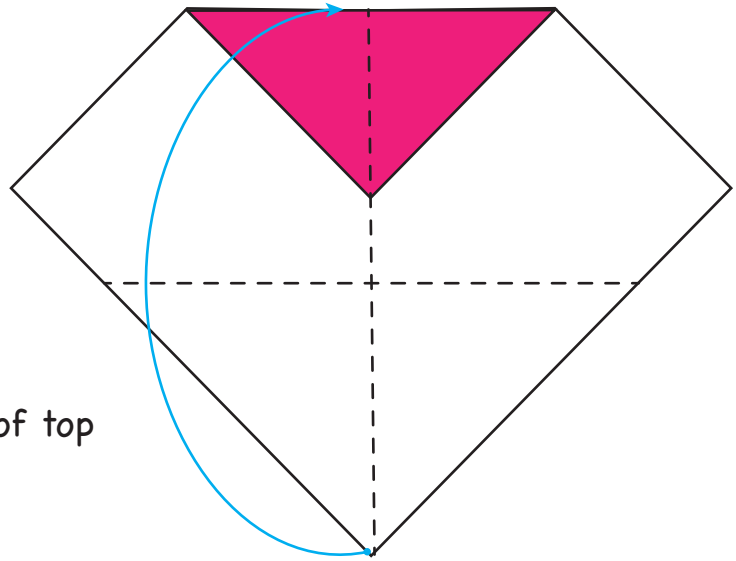

1. Bring bottom corner to center of top edge.
2. Crease the fold.
3. Notice that the perpendicular lines are the same length.

© 2023 UnCommon-Core.com



4

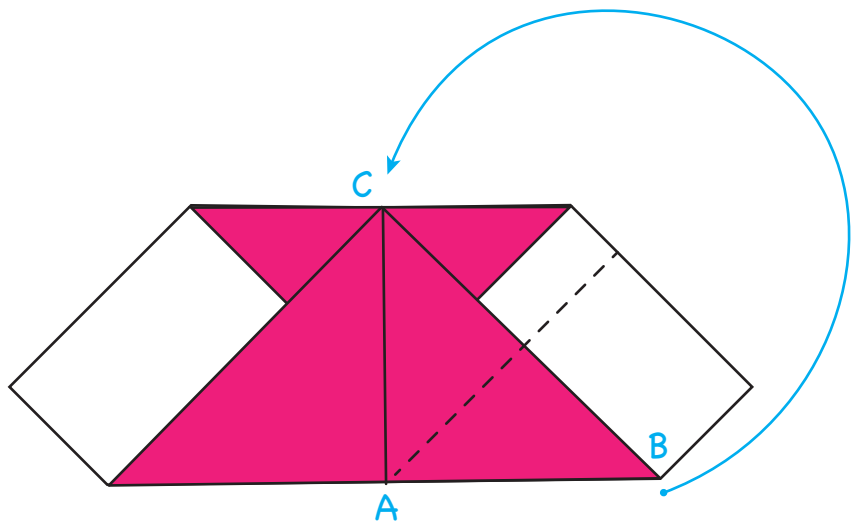

1. Use point A as a pivot.
2. Bring point B up to meet the center of the top edge at point C.
3. Match \overline{AB} to \overline{AC} very carefully.
4. Crease.

© 2023 UnCommon-Core.com

5

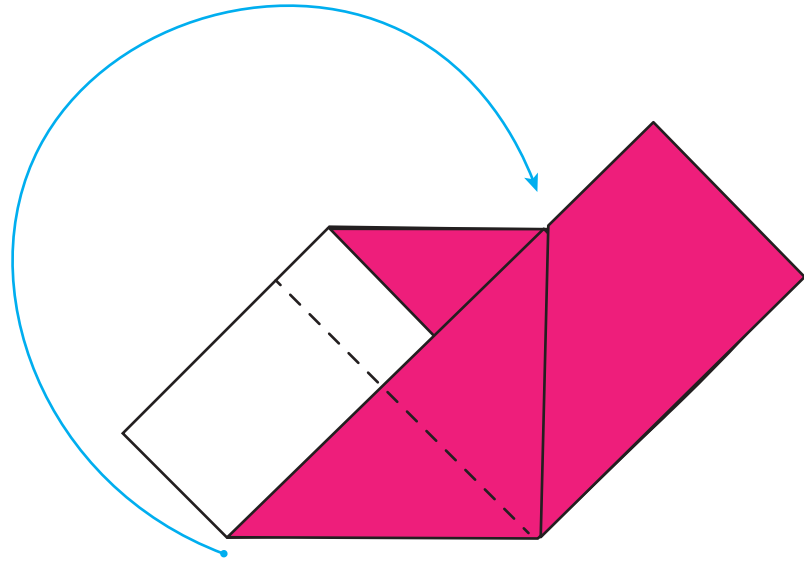

1. Repeat step 4 on the other side.

© 2023 UnCommon-Core.com



6

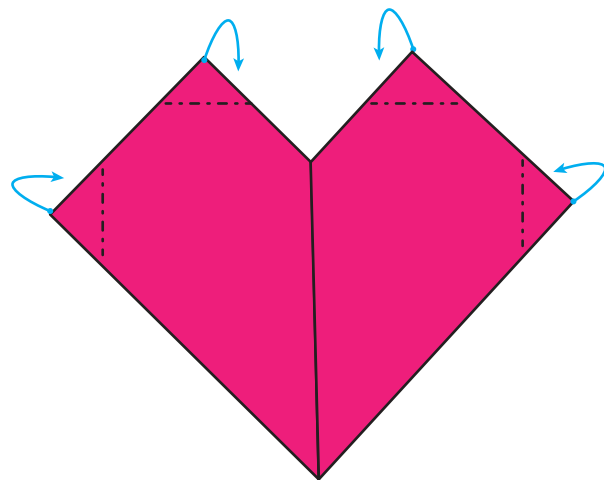

1. Fold the tip of each corner to the back as shown.
2. Write your name or initials on the back of your paper heart.
3. Try folding another heart from memory.

© 2023 UnCommon-Core.com

Fold a Valentine

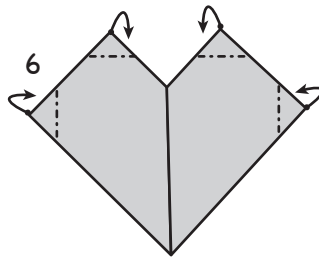
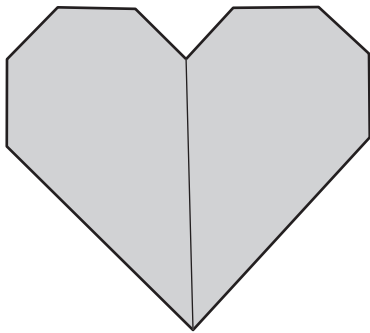
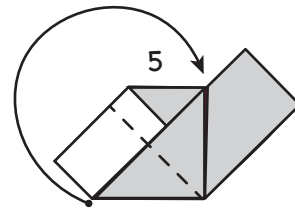
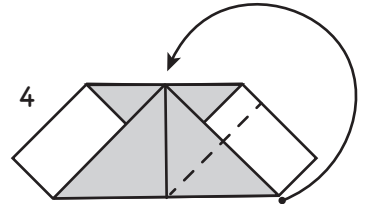
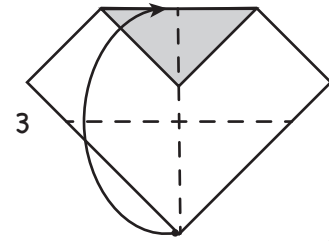
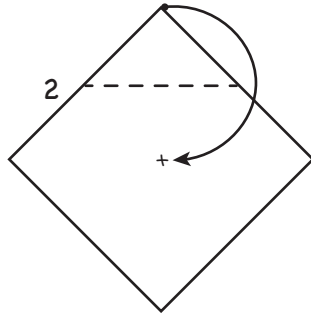
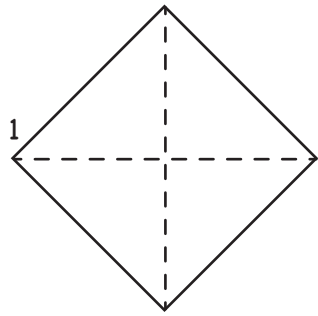

© 2023 UnCommon-Core.com

Fold a Valentine

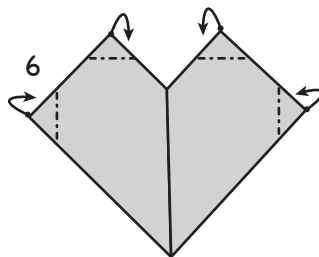
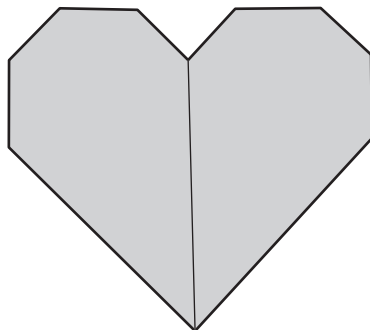
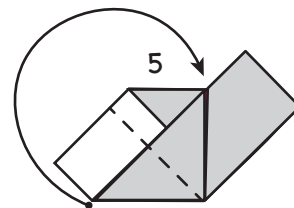
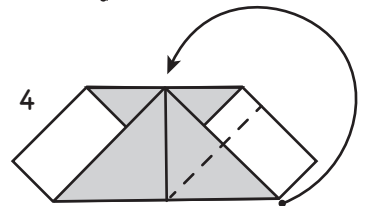
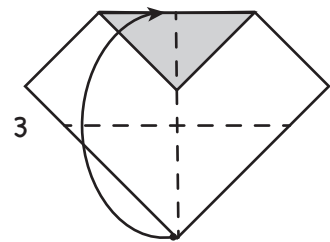
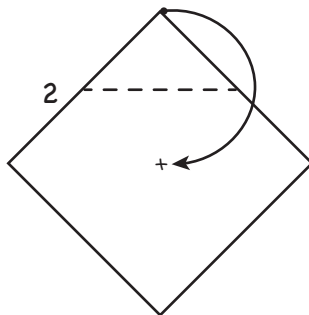
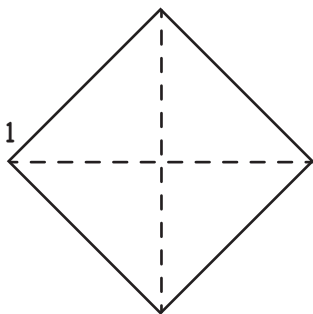

© 2023 UnCommon-Core.com



Fold a Valentine

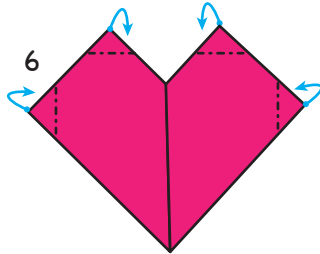
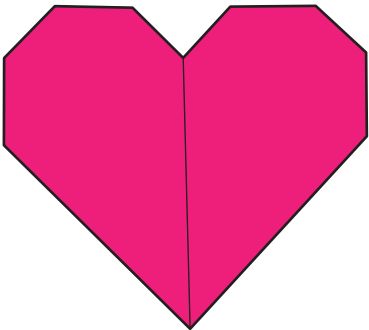
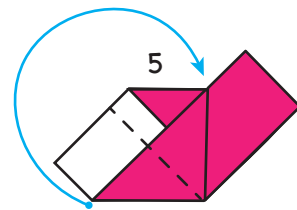
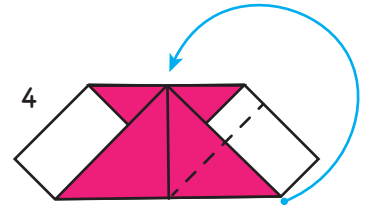
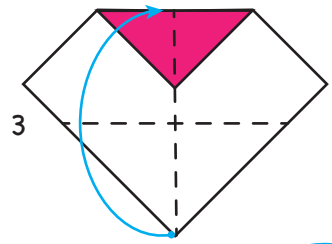
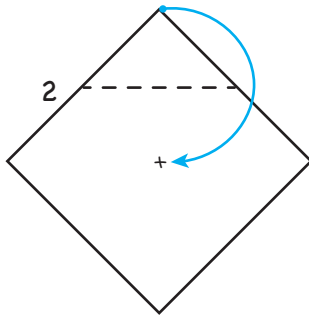
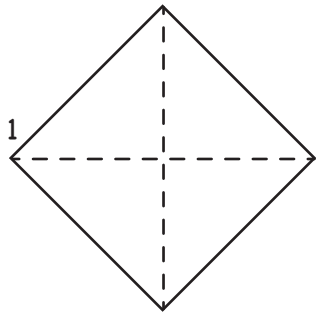

© 2023 UnCommon-Core.com

Fold a Valentine

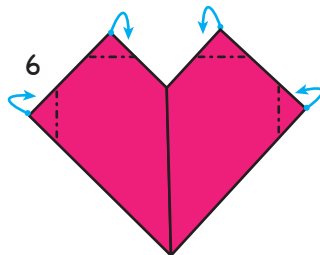
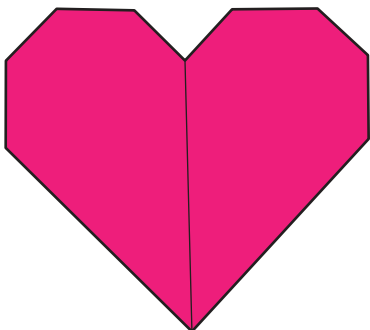
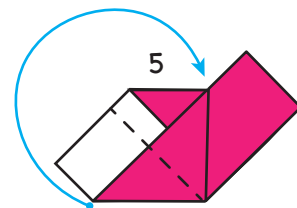
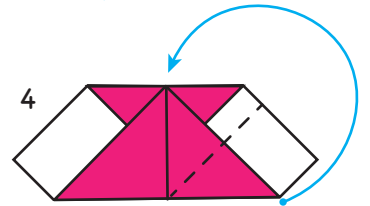
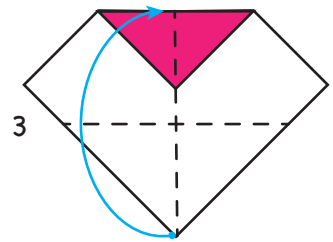
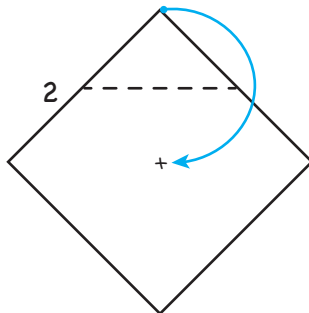
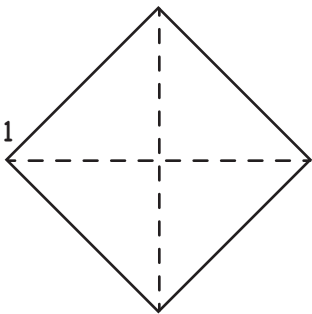

© 2023 UnCommon-Core.com



Rebus Valentine

name: _____

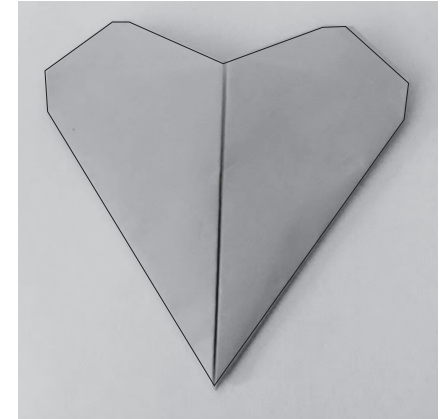
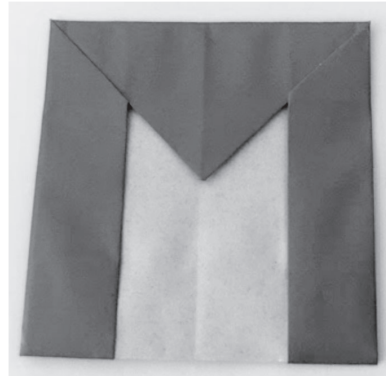
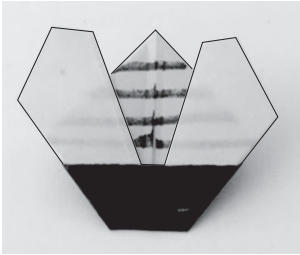

© 2023 UnCommon-Core.com

Be my valentine.

Teachers! Cut this part off before sharing with your students. Young students could trace inside the letters then paste the words under the pictures. (Cut the words apart.) Older students could write the words. Invite everyone to make their own rebus sentences. Enjoy!

Rebus Valentine

name: _____

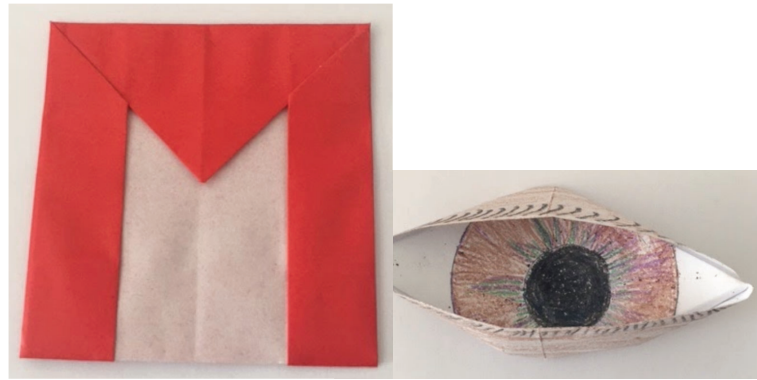
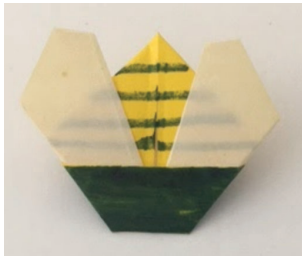

© 2023 UnCommon-Core.com

Be my valentine.

Teachers! Cut this part off before sharing with your students. Young students could trace inside the letters then paste the words under the pictures. (Cut the words apart.) Older students could write the words. Invite everyone to make their own rebus sentences. Enjoy!

Terms of Use

By downloading this product, you agree that the contents are the property of Isabelle Hoag M. Ed., Director of Education at UnCommon-Core.com and licensed to you only for classroom/personal use as a single user. I retain the copyright, and reserve all rights to this product.

YOU MAY:

- Use this product with your own students, in your classroom, or for your own personal use.
 - Reference this product in blog posts, professional development workshops, at seminars, or other similar venues, ONLY if both credit is given to me as the author and a link to UnCommon-Core.com is included.
 - Please direct others to UnCommon-Core.com where they can download their own free copy.
-

YOU MAY NOT:

- Claim this work as your own, alter the files in any way or remove copyright/watermarks.
 - Sell the files or combine them into another unit for sale or for free.
 - Post this document for sale or free elsewhere on the internet including Google Doc links on blogs.
 - Make copies of this product to share with others.
-

Thank you for following universally accepted codes of professional ethics while using this product. If you have any issues with the file, or notice an error please contact me and I will be happy to help sort it out.

Thank you!

Isabelle@UnCommon-Core.com